

香港非物質文化  
遺產代表作—  
中秋節—薄扶林  
舞火龍



小學常識科

各位同學好，我是  
倉鼠教授。  
正式上堂前，有一個  
問題考考大家……



中秋節  
會做什麼？





賞月？



吃月餅、玩燈籠？

# 中秋節時同學們都會做什麼呢？



安坐家中？



還是...

# 在薄扶林村...

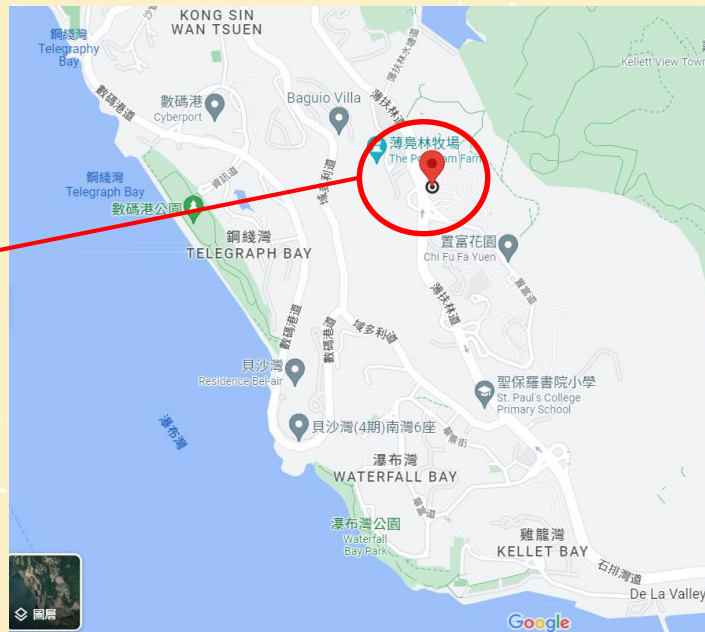

每逢中秋節晚上，薄扶林村民均舉行舞火龍活動。



薄扶林村火龍會紀錄片 — 龍情·薄扶林 (03:04~04:25)

<https://youtu.be/Q3qRuQvAL7w?t=184>

## 什麼是 「舞火龍」呢？

看完影片後，嘗試為以下兩題  
找出答案吧！

1. 「龍」對於中國傳統文化中  
有何意義呢？
2. 為什麼薄扶林村民要「舞火  
龍」呢？

# 什麼是「舞火龍」呢？

1. 「龍」對於中國傳統文化中有何意義呢？

- **權威**的象徵
- 人們對於「龍」亦十分**尊崇**



2. 為什麼薄扶林村民要「舞火龍」呢？

- 以往薄扶林村村民以**畜牧**（養豬、養雞）、耕種為生…
- **瘟疫** ☹️
- 認為藉助

「龍」請求**神明保佑** + 「火」可以**燒走瘟疫**

→ 消災解難 ☺️





# 「舞火龍」習俗的來源?

很久很久以前…19世紀末在薄扶林村的一場瘟疫…

當時居民以禾草紮成龍的形態，龍身插滿燃點的香枝，巡遊全村。



# 「舞火龍」習俗的來源? (續)



當時村民的目的：

1. 祈求透過「火龍」**祛災除病**，**淨化**村落。

後來瘟疫消退了…

2. 村民認為「舞火龍」的儀式有效，且  
令人**安心**

→ 「舞火龍」習俗**被保留**下來。



# 為什麼「舞火龍」儀式 會選擇在中秋節舉行？

中秋節：**團聚**

- 村內人數最多的時候
- 現今薄扶林舞火龍活動在**中秋節前夕**  
**及正日晚上**進行。



- 數十名健兒舞動火龍，拜訪**每家每戶**，為村民帶來**好運**，祈求**身體安康**。



## 小總結：

「舞火龍」習俗的來源？

- 19世紀末的一場瘟疫

「舞火龍」的象征意義？

- 龍=權威 → 神明保佑
  - 火=燒走瘟疫
- 主要意義：**消災解難、使村民安心**



# 動動手！ 設計「火龍」 小活動



假如你們是薄扶林村村民，並需要為今年度中秋  
「舞火龍」活動設計火龍的樣子，  
你會怎麼設計呢？  
跟同學們討論看看，然後發揮你的創意畫出來吧！





# 「火龍」的 設計過程？



每年中秋，薄扶林村民都會大舞火龍。



來看看薄扶林村的「火龍」  
是怎麼製作出來吧！☺



# 火龍紮作五部曲



薄扶林村的火龍紮作師傅吳江乾先生訪問-(01:36-05:10)

影片連結:

<https://www.youtube.com/watch?v=zMXYq5U8oiU>

# 火龍紮作的基本材料有：



竹



禾草

材料有！





# 火龍紮作五部曲

## 第一步：破竹、削竹



破竹器



- 破竹器的用法是將破竹器平放在竹端上，上至下分開竹子。



# 火龍紮作五部曲

## 第二步：製作支架

火龍支架分龍頭、龍身和龍尾三部分。



支架製作：龍頭



龍的五觀多使用具弧度的竹條…

支架製作：龍頭

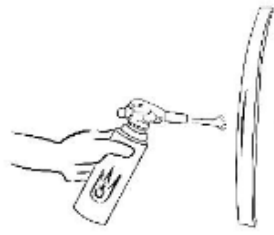

用火槍略烤竹條  
→火的熱力軟化竹條  
→塑形

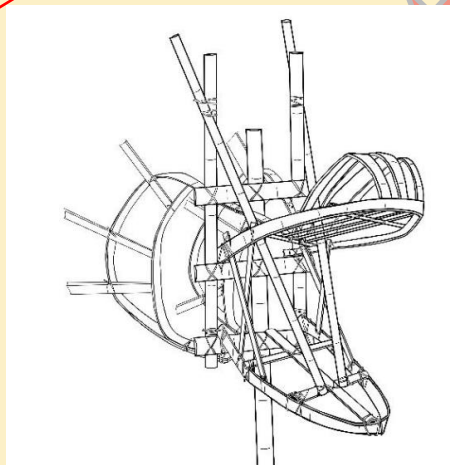

吳師傅表示：以前的火龍外形比較簡單…都是經過他不停的改良才形成今天的樣子。





# 火龍紮作五部曲

## 第三、四步：鋪禾草、裝飾



紮好龍架後，分別在龍頭和龍身上鋪上禾草，再用鐵線將禾草紮實在粗繩上。

紮龍尾



# 第五步：「舞火龍」前...插香、點睛



**插香**才叫「火龍」啊！

**火龍點睛**：開天眼！





# 思考時間：

同學看完影片後，覺得應該全盤套用  
同學們新的設計去取代舊有設計，還  
是可以融入你們的設計到  
傳統工藝中呢？





- 吳師傅曾經有提及：「**創新不忘本**」
- 他認為相信舞火龍活動可以**一代傳一代** ➡
- 保留傳統紮火龍的**技藝**，才算**保留文化**的「**根**」，才可以**保留「舞火龍」傳統風俗**的歷史。

- 文化的傳承 = 歷史傳承的一種
- 「保育」文化



THANK  
YOU





# 參考資料

香港浸會大學歷史系：〈香港非物質文化遺產代表作名錄：中秋節——薄扶林舞火龍 研究計劃〉，<https://digital.lib.hkbu.edu.hk/history/firedragondance/>（2022年8月1日讀取）。

中國文化研究院：〈通識·現代中國：薪火相傳 香港非物質文化遺產/薄扶林舞火龍〉，<https://ls.chiculture.org.hk/tc/passing-the-torch/368>（2022年8月1日讀取）。



薄扶林村火龍會：〈薄扶林村火龍會紀錄片 — 龍情·薄扶林〉，<https://www.youtube.com/watch?v=Q3qRuQvAL7w>（2022年8月1日讀取）。

非物質文化遺產辦事處：〈香港首份非物質文化遺產清單〉，[https://www.lcsd.gov.hk/CE/Museum/ICHO/zh\\_TW/web/icho/the\\_first\\_intangible\\_cultural\\_heritage\\_inventory\\_of\\_hong\\_kong.html](https://www.lcsd.gov.hk/CE/Museum/ICHO/zh_TW/web/icho/the_first_intangible_cultural_heritage_inventory_of_hong_kong.html)（2022年8月1日讀取）。

